

Instruction Manual



D&RGW T-12 4-6-0 Electric & Live Steam



ACCUCRAFT TRAINS
MUSEUM QUALITY BRASS MODELS

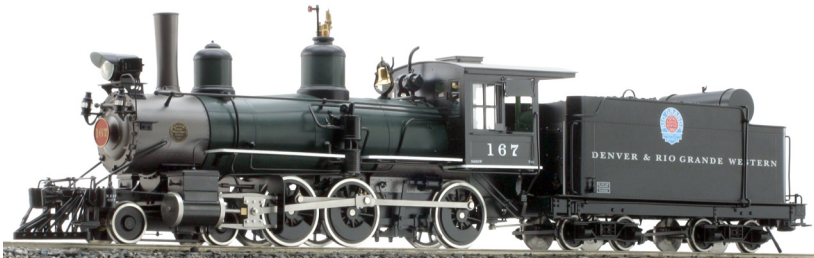

Prototype Information

Denver and Rio Grande Western Class T-12 was built in 1883 by Baldwin Locomotive Works for the Denver and Rio Grande Railroad. It was built as a passenger locomotive with 46" drivers, the second largest drivers used on any three foot gauge D&RGW locomotive. During its service career it was used on all of the major D&RGW narrow gauge lines. It was taken out of service in 1938 and then refurbished in 1939 to appear at the 1939 New York World's Fair.

The live steam model is internally gas fired and is constructed with brass and stainless steel. It should pull up to a dozen standard-size freight cars on good level track. Grades and sharp curves will diminish its capability. A good engineer will learn the engine's characteristics and idiosyncrasies over time, to get the best performance and longest duration from it.



Lubrication

Lubricants: always use quality lubricants!

Light oil such as Labelle #108 or Wahl Clipper Oil. Heavy lubricant such as Labelle #102 heavy gear oil or Labelle grease.

Prepare the engine for lubrication by placing the model gently on the work surface. To protect the locomotive finish, place the engine on a piece of foam sheet or soft towel. The engine should be placed on its side. Be careful to keep the lubricant off of the painted surfaces, as this can leave a shiny appearance on the area it touches.

Oil all external moving parts of the engine, including wheel bearings, with a high grade, lightweight machine oil like 3-in-1. Be sure to oil all parts of the drive train. A little oil is all that's necessary.

It is a good idea to wipe off all excess light oil when you complete the lubrication process.

THIS LUBRICATION SHOULD BE REPEATED AFTER EVERY 25 HOURS OF OPERATION!

After following the recommended lubrication procedures, your "T-12" is ready to provide many years of enjoyment and reliable operation. We recommend that you use a D.C. power supply with a capacity of 2.5 amps or larger and 24 volts.

Always pick your model up by grasping it under the frame on both ends. It is a very heavy model so make sure that you grasp it firmly.

General maintenance

Clean the exterior surfaces of your locomotive with a clean, soft and lint free cloth.

The following parts are packaged separately

- M2 hex head screws
- 3 mm hex head screw driver
- Whistle pull cord

T-12 Electric



Please note the following diagram is for installation of aftermarket sound system or smoke unit.

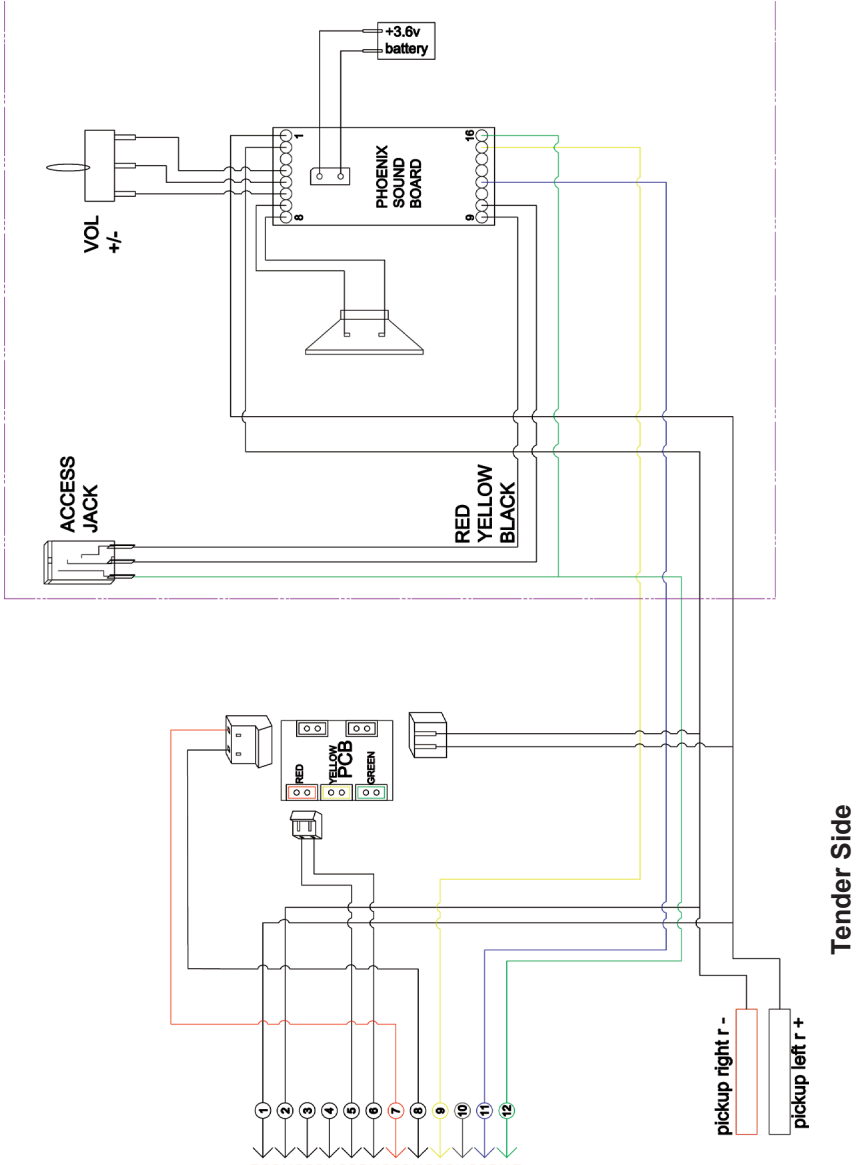

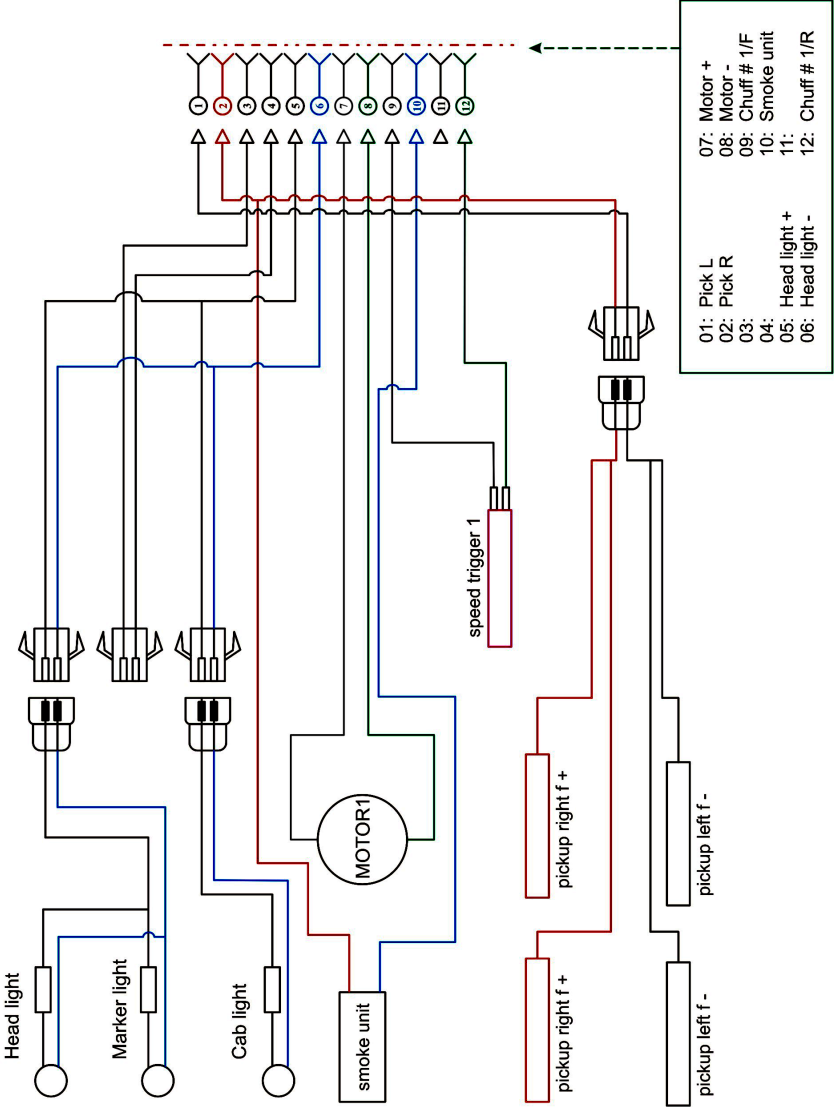

Loco Side



Preparing the engine

A steam-locomotive engineer goes through a lighting-up ritual every time the engine is to be run. It is good to follow the same routine each time so that nothing is overlooked.

1. Oil all external moving parts of the engine, including wheel bearings, with a high grade, lightweight machine oil like 3-in-1. Be sure to oil all parts of the drive train. A little oil is all that's necessary.

2. Place the engine on track.

3. The adjustable lubricator located in the cab ensures the cylinders and valves are properly lubricated inside. As the steam passes through it, a small amount will condense into water. This water will sink to the bottom of the lubricator, forcing a similar quantity of oil into the steam line and thus to the cylinders.

Remove the lubricator cap and draw out any water from previous run with a syringe. Use only proper steam cylinder oil. Fill the lubricator, but leave a small air space between the oil and the cap.

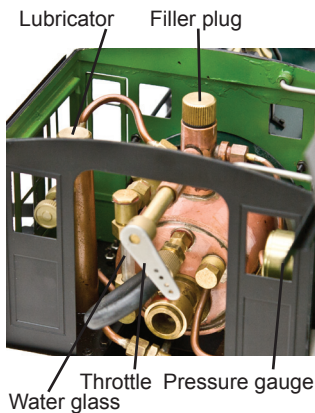



4. Unscrew the filler plug and fill the boiler to the top with water then pull out 30 ml with large syringe. Use only distilled water in your engine's boiler. Tap water contains minerals that will leach out and ultimately affect the performance of the engine.

5. Finally, add fuel. Your T-12 burns butane gas. The gas tank is located in the tender beneath the front hatch. Butane gas can be purchased at the grocery store or at a tobacconist's as cigarette-lighter refills. These come with a nipple suitable for the filler valve on the T-12's gas tank. (Butane can also be purchased in larger containers at camping-supply stores, but these cans will require a special adapter for filling the engine's tank.) Simply press the nozzle of the butane canister hard onto the filler valve atop the tank, making sure that the control valve is closed. You will hear the gas transferring and will see a little gas bleeding out of the valve. When the tank is full, the gas will begin to splutter and much more gas will escape the valve. When the gas tank is full you are ready to fire up the engine. Add 1" to 2" of water to the rear tank. This will keep the tank warm and the gas pressure up!

Firing up

Make sure the throttle is closed. The engine's burner resides at the back of the flue inside the boiler. Open the hinged smokebox door at the front of the engine and you'll be able to see the flue. To light up, strike a match and hold it at the open smokebox door while simultaneously opening the gas valve in the tender very slowly until the gas ignites. You should hear the gas coming into the burner. Opening the valve too wide or too fast may blow out the flame or cause the fire to burn in the smokebox.

The fire should flash back into the back of the flue with a quiet "pop". If it wants to burn in the smokebox or in the forward part of the flue, slowly close the gas valve until it flashes back to the burner. Don't let the fire burn in the smokebox - your engine will not run as it should and may be damaged. The fire should burn under the burner in a crescent-shaped flame, which should be clearly visible through the smokebox door. The flame should be bright blue and should burn steadily. If it sputters or looks yellow or green, adjust the gas valve accordingly. The object is to run the burner at the lowest setting possible to operate the engine, thereby increasing the efficiency of the engine and the duration of the run. You'll get the hang of this with practice.



After another four or five minutes, pressure on the pressure gauge should read about 20psi (pounds per square inch) or so. The safety valve is set at 60psi. When the pressure on the gauge reaches 40psi, the engine can be run.

Running

Open the cab roof for access to the controls. Move the reversing lever at the right side of the cab to the forward position. With the engine on the track, and without a train, open the throttle. Because the cylinders are cold, the hot steam entering them will condense into water and be exhausted through the stack. The engine may need to be pushed a little to overcome the steam condensing into water in the cold cylinders. After a few moments, it should take off on its own, moving away smoothly.

Once the engine is running smoothly, a train can be coupled on and the run can proceed. Since all of the locomotive's functions are controlled from the cab, it can be driven like a full-size engine, meaning that you'll have to stay with the engine through the run if you want to change its speed or direction. If you have a suitable track, the engine can be left to run on its own at a steady speed. Keep your eye on the water glass. When the water level drops, add water by pumping the hand pump.

Shutting down

At the end of the day's run, close the throttle snugly. When cool, the safety valve should be loosened to relieve the vacuum that will be created in the boiler. This vacuum could pull oil from the lubricator into the boiler if the throttle is not closed.

After a day's operation in the garden you'll probably find that your engine has a coating of oil all over it. This is steam-cylinder oil that has been exhausted from the stack. A simple wipe down with a dry cloth is all that's necessary to restore the engine to pristine condition. This is best done while the engine is still hot. Wipe any grit and excess oil from the wheels and running gear.

The boiler can be drained of water, or not, as you will. Leaving water in the boiler will not harm it. The lubricator can also be drained and refilled with steam oil in preparation for the next run.

Cold-Weather Running

The weather can dramatically affect the performance of your locomotive. Cold and wind can decrease efficiency to a disappointing level. Butane gas becomes liquid at 32°F and will not work. As it approaches 32°F, its pressure (and effectiveness) diminishes.



The compartment in the rear tank in which the gas tank resides can be filled with warm water in cooler weather. This will warm the gas in the tank and keep its pressure up, which will cause the engine to operate in a much more lively manner, much as it does in warm weather. If the water in the tank cools, just replace it with warmer water. Empty the tender at the end of the day's run. Note: the temperature of the fuel-supply-can must always be higher than that of the engine's gas tank. If you have warmed the engine's gas tank and the supply can is cooler, gas will not transfer. Never put boiling hot water in the tender around the fuel tank.

Notes on Radio Control

Although the T-12 was designed as a manually controlled locomotive, there is no reason why radio control (R/C) cannot be fitted, with some ingenuity. A two channel radio is all that's necessary, one for the throttle and one for the reversing lever. The gas valve should always be controlled manually. The reversing lever will have to be modified so that it does not lock in position, but it must still have stops at either end of its throw for proper positioning of the reversing valve.

Safety

For your safety, there are certain rules that should be observed, as follows:

1. The safety valve is under the steam dome (the dome nearest the cab). It has been set at the factory to release at 60 pounds per square inch of pressure. Never tamper with the safety valve.
2. The firing system has been designed to use butane gas only. Never use any other gas (including propane or butane/propane mix), as the storage pressures can reach unsafe levels.
3. Always refuel the engine away from other working live-steam locomotives. The fuel filling system allows a small amount of the gas to bleed off as the fuel tank is being filled. A passing engine can ignite this bleed-off gas, causing a potentially hazardous situation.
4. When lighting up, light your match first, then turn on the gas.
5. A steam engine gets hot. Be careful. The following parts are packaged separately
 - M3 hex head screws
 - 3 mm hex head screw driver
 - 5 ml syringe – steam oil
 - 50 ml syringe - water



Technical Specifications

Live Steam

Scale/Gauge: 1:20.3, 45 mm Gauge

Length: 31.34 in. (796 mm)

Width: 4.45 in. (113 mm)

Height: 7.01 in. (178 mm)

Minimum Radius: 48 ins. 1.2 M

*Be sure to leave at least 3" clearance (measured from the inner rail) to allow for overhang.

Caution!

This model is an accurate replica of the original locomotive. It has sharp and moving parts. The locomotive drive rods are stainless steel with sharp edges. **AT ANY TIME, OPERATORS MUST NOT COME IN CONTACT WITH THE MODEL WHILE IT IS POWERED. UNDER NO CIRCUMSTANCES SHALL ACCUCRAFT TRAINS BE RESPONSIBLE FOR ANY INCIDENTAL OR CONSEQUENTIAL DAMAGES ARISING IN REGARD TO ANY ACCUCRAFT PRODUCT.**

Accucraft Trains locomotives are fine scale brass models with small parts. To provide maximum protection from shipping damage, we carefully pack the models in metal cases. We ship via UPS with insurance coverage to its full value. Please contact UPS if package is damaged.

Each locomotive is packed under UPS guideline for shipping. We do not warrant any damage resulted from re-packaging by any party other than Accucraft Trains.

Please read following directions before unpacking your locomotive.

1. Lift the box from the cardboard box.
2. Place taped locomotive on a flat surface. Carefully cut the tape along the wood board side surface. Be sure to cut both sides of the wood board. Slowly lift the tape from the locomotive. Be very careful with small parts. Tape cannot be re-used to re-pack the model. Use new packing tape if necessary.

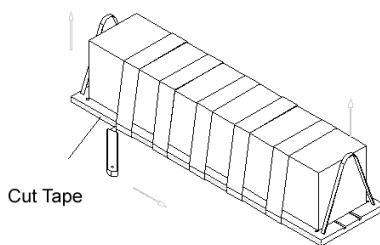





ACCUCRAFT COMPANY
33268 Central Avenue
Union City, CA 94587
Tel: 510-324-3399
Fax: 510-324-3366
Email: info@accucraft.com
Copyright 2012